

OPTION

Spot-On

LoRa

PARKING SENSOR SPS200



- Parking sensor ideal for Smart City applications in combination with actuators such as Smart Public Lighting and EV-charging stations.
- On-surface parking sensor to detect the presence of vehicles above the sensor.
- Magnetic sensor and 60 GHz radar sensor assure reliable operation with long battery autonomy.
- Low power, long range communication to data backend.
- Open API enabling Cloud Platform access.
- Over-the-air configuration.
- Integrated NFC connection to allow local control and configuration.
- Battery lifetime up to 10 years.

OPTION

Operation

After mounting, the parking sensor is activated via NFC technology. Its built-in magnetic sensor will continuously monitor changes in the magnetic field caused by the movement of vehicles.

The parking sensor's built-in radar sensor will then confirm when a vehicle is positioned above the sensor.

This algorithm ensures optimal use of the battery while maintaining high accuracy. The battery level is periodically monitored and sent to the back-end server at a configurable interval.

Radar and magnetic detection enable operation under extreme weather conditions including sensor cover e.g. leaves, snow, ...

Use case scenarios

- Detect when parking spots for electric vehicle charging are used by vehicles that are not using the EV charging infrastructure.
- Guide vehicles to the available parking spaces.
- Monitor the occupation of short-term parking spaces to detect parking duration violations.

Dimensions

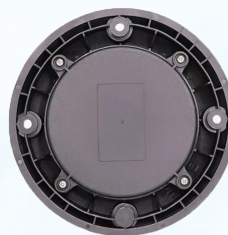
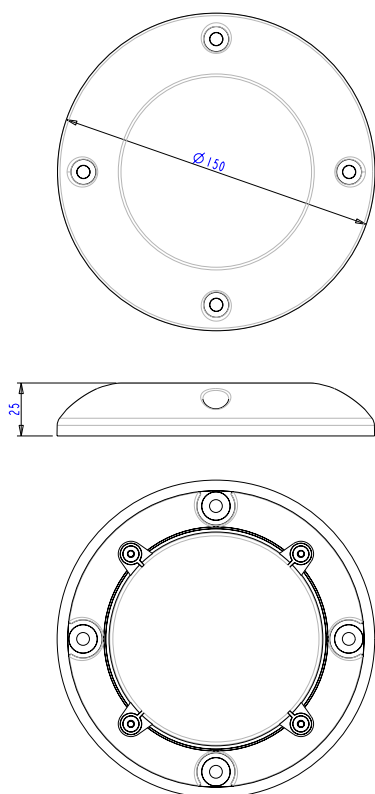

2 independent sensor principles

Technical Specifications

Physical information	Dimension	150 mm diameter x 25 mm height
	Colour	Black
	Mounting	4 mounting holes
	Material	Nylon
	Weight	300 g
	Max load	5 - 10 tonnes
	IK class	IK7
Electrical information	Battery	Triple-pack AA size (LiSOCl ₂ , 3.6V, 8100 mAh)
	Autonomy	Up to 10 years when <ul style="list-style-type: none"> • Max 50 in/out movements per day • Good LoRaWAN signal conditions (SF9, or better)
Technology information	LPWAN modem	LoRaWAN <ul style="list-style-type: none"> • 868 MHz or 915 MHz regions • Integrated PCB antenna • LoRaWAN protocol 1.0.3. • LoRaWAN class A • Activation method: OTAA
	Magnetic sensor	Earth magnetic field (high-accuracy, 3-axis digital output magnetometer)
	Pulsed Coherent Radar	<ul style="list-style-type: none"> • 60 GHz • Detection distance between 30 - 600 mm
	Integrated NFC tag	ISO/IEC 15693
Environmental information	Operating temperature	-20°C to 60°C
	Humidity	5% to 95% relative humidity (non-condensing)
	IP class	IP68
Certification	CE Radio Equipment Directive 2014/53/EU, RoHS/REACH, WEEE	

Product	PN
Spot-On SPS200	SE0103-12237

DISCLAIMER

All product specifications are subject to change without notice.