

White Paper



# Power Considerations for 2G & 3G Modules in MID Designs



**Confidentiality**

All data and information contained or disclosed by this document is confidential and proprietary of Option NV, and all rights therein are expressly reserved. By accepting this document, the recipient agrees that this information is held in confidence and in trust and will not be used, copied, reproduced in whole or in part, nor its contents revealed in any manner to others without prior and written permission of Option NV.

## Contents

|       |  |    |
|-------|--|----|
| 1     | Introduction                                 | 2  |
| 2     | General Overview                             | 3  |
| 3     | Power Consumption                            | 4  |
| 3.1   | Power Consumption in 2G and 3G               | 4  |
| 3.1.1 | 3G Power Classes according to 3GPP           | 4  |
| 3.1.2 | 2G Power Classes according to 3GPP           | 4  |
| 3.1.3 | 3GPP Power Management Enablers               | 5  |
| 3.1.4 | Idle Mode in 3GPP                            | 5  |
| 3.2   | Current Vs Power Output                      | 6  |
| 3.2.1 | Current Consumption in idle state            | 6  |
| 3.2.2 | Current Consumption in 2G in connected state | 6  |
| 3.2.3 | Current consumption in 3G in connected state | 7  |
| 4     | Design Guidelines                            | 8  |
| 4.1   | Antenna Mismatching                          | 8  |
| 4.2   | Load Transient in Mobile Internet Devices    | 9  |
| 5     | Conclusion                                   | 10 |
| 6     | About Option                                 | 11 |
| 7     | Reference                                    | 12 |
| 8     | Glossary                                     | 12 |

## 1 Introduction

This document focuses on power consumption of 2G/3G embedded wireless modules integrated in Mobile Internet Devices (MIDs). It considers the fact that this has an impact on the MID's power supply to the wireless module.

MIDs that have embedded 2G/3G modules have different behaviour from MIDs with other wireless connectivity technologies embedded (WLAN, WiMAX). The root cause of this behaviour is the nature of signal traffic in 2G/3G environments. In 2G environments bursts of traffic can be followed by periods of inactivity.

This document starts by providing a general overview of the main components of Mobile Internet Devices. The following chapters give a general explanation of how a module behaves according to 3GPP when it is in idle state and in a connected state. The document also provides information on power consumption in 2G and 3G.

Also included are guidelines for the MID manufacturers regarding potential improvements to their devices for optimal current consumption. This is done by explaining the main characteristics that can have an influence on current consumption in an MID, and areas where Option (as an embedded module manufacturer) has no control over, for example antenna mismatching and non-optimised load transients.

The target audience for this document is 2G/3G wireless module integrators.

## 2 General overview

The diagram below summarises the different components involved with Mobile Internet Devices, pinpointing the areas where the designer needs to pay extra attention:

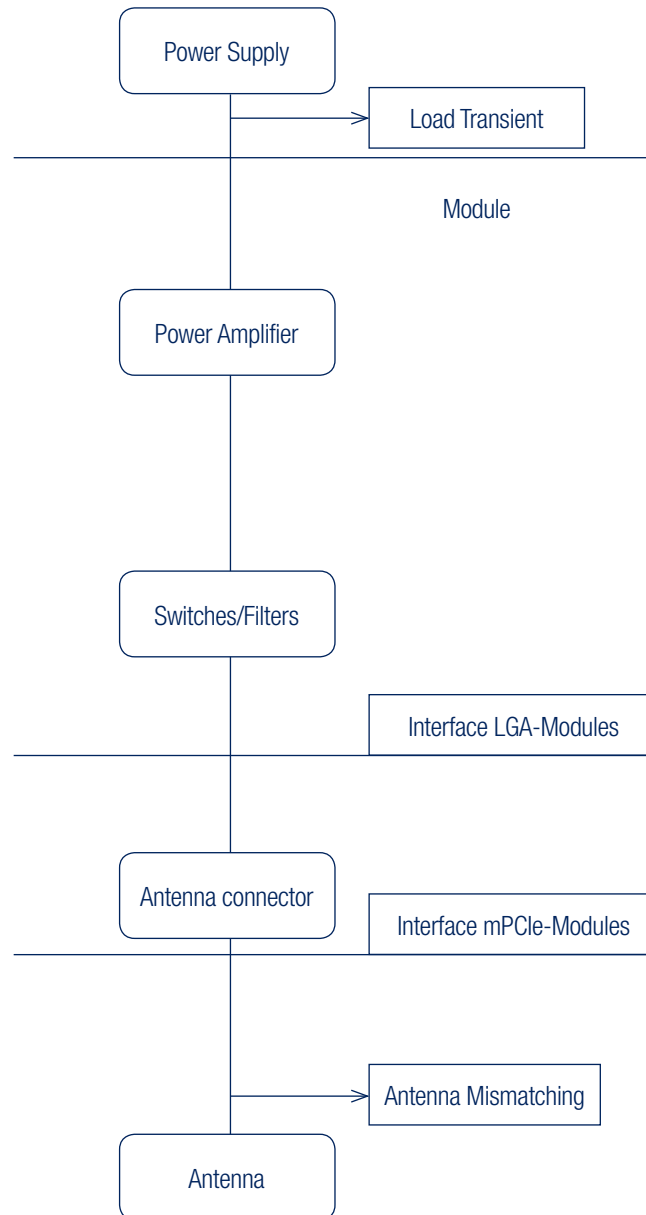

### 3 Power consumption

This section gives a technical explanation of power consumption in 2G/3G based on ETSI specification. Section 2.1 translates this information into real time environments to demonstrate what the current consumption will be in real time behaviour.

#### 3.1 Power Consumption in 2G and 3G

This section shows the different power classes of a UE in 2G and 3G according to 3GPP specifications.

##### 3.1.1 3G Power Classes according to 3GPP

The nominal maximum output power and its tolerance are defined according to the power class of the UE.

The maximum output power is a measure of the maximum power the UE can transmit (i.e. the actual power that would be measured assuming no measurement error) in a bandwidth of 4.25MHz times the chip rate of the radio access mode. The measurement should last at least one timeslot. The requirements and this test apply to all types of UTRA for the FDD UE.

| Operating Band | Power Class 1 |           | Power Class 2 |           | Power Class 3 |           | Power Class 4 |           |
|----------------|---------------|-----------|---------------|-----------|---------------|-----------|---------------|-----------|
|                | Power         | Tol (dB)  | Power         | Tol (dB)  | Power (dBm)   | Tol (dB)  | Power (dBm)   | Tol (dB)  |
| Band I         | +33dBm/2W     | +1.7/-3.7 | + 27dBm/0,5W  | +1.7/-3.7 | +24dBm/0,25W  | +1.7/-3.7 | +21dBm/126mW  | +2.7/-2.7 |
| Band II        | -             | -         | -             | -         | + 24          | +1.7/-3.7 | +21           | +2.7/-2.7 |
| Band III       | -             | -         | -             | -         | + 24          | +1.7/-3.7 | +21           | +2.7/-2.7 |
| Band IV        | -             | -         | -             | -         | + 24          | +1.7/-3.7 | +21           | +2.7/-2.7 |
| Band V         | -             | -         | -             | -         | + 24          | +1.7/-3.7 | +21           | +2.7/-2.7 |
| Band VI        | -             | -         | -             | -         | + 24          | +1.7/-3.7 | +21           | +2.7/-2.7 |

All Option modules fall into 3G Power Class 3 with a maximum defined output power of +24dBm (0.25W).

##### 3.1.2 2G Power Classes according to 3GPP

|          | Power Class 1 | Power Class 2 | Power Class 3 | Power Class 4 | Power Class 5 |
|----------|---------------|---------------|---------------|---------------|---------------|
| GSM 900  | 43 dBm(20W)   | 39 dBm(8W)    | 37 dBm(5W)    | 33 dBm(2W)    | 29 dBm(0.8W)  |
| DCS 1800 | 30 dBm(1W)    | 24 dBm(0.25W) | 36 dBm(4W)    | 43 dBm(20W)   | 43 dBm(20W)   |

All Option modules are Power Class 1 for the higher bands (DCS 1800) and fall into Power Class 4 in lower bands (GSM 900).

### 3.1.3 3GPP Power Management Enablers

The state diagram underneath shows in detail the different states that exist in 2G/3G. These states can be split into two main modes: Connected Mode/ Packet Transfer Mode and Idle Mode.

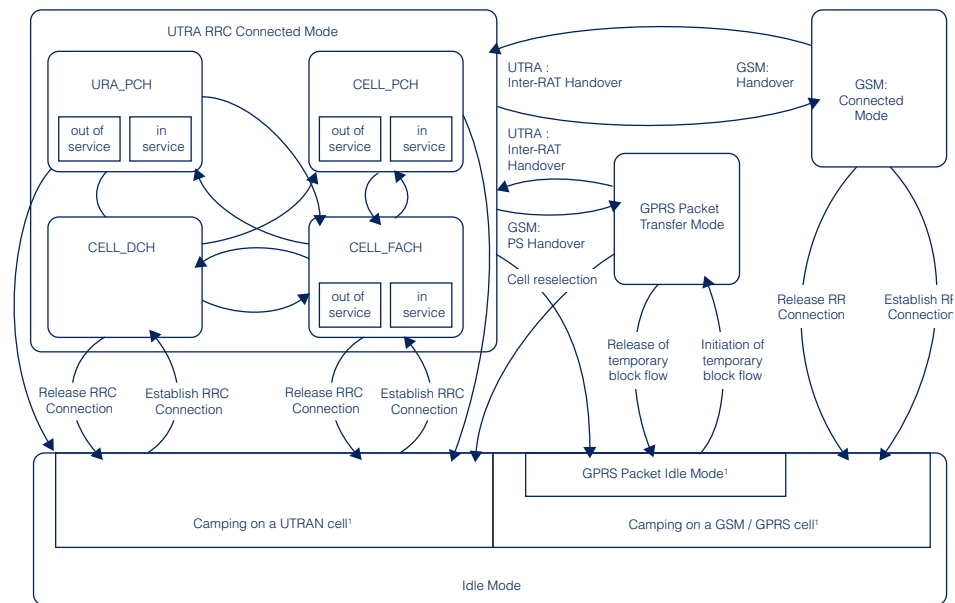

### 3.1.4 Idle Mode in 3GPP

Idle Mode in 3GPP consists of:

**Not Registered:** Module has to scan and camp, then register on a cell. The radio's TX/RX have to be on continue to support the process until the camping completes. No registration or channel is available. (Power consumption is high during this period).

**Registered on a GSM/GPRS cell:** When the module is registered, it has to support control signaling for paging, mobility management and other activities. No bearer channel is established. (Power consumption is relatively low during this period.)

**Sub-state: GPRS Packet Idle Mode:** When the module is registered, it has to support control signaling for paging, mobility management and other activities. The bearer channel has been established. The TX/RX does not carry bearer services. (Power consumption is relatively low during this period).

**Registered on a UTRAN cell:** When the module is registered, it has to support control signaling for paging, mobility management and other activities. Bearer channel may be established. (Power consumption is relatively low during this period).



### 3.2 Current Vs Power Output

This section discusses the Current versus Power Output measurements of the Option module in different scenarios, in a connected state (GSM, GPRS, EDGE, WCDMA and HSDPA) and also in an idle state.

#### 3.2.1 Current Consumption in idle state

In idle state the current consumed is:

| Status            | Typical measured Current |
|-------------------|--------------------------|
| Radio Powered off | 2.2mA                    |
| 2G IDLE           | 3.3mA                    |
| 3G IDLE           | 4.3mA                    |

#### 3.2.2 Current Consumption in 2G in connected state

In 2G, the most important point to be noted is that the average current is not equal to the high current. This is because of the nature of traffic in 2G coming in bursts. The figure below shows a typical behaviour. It indicates that during traffic coming in bursts, the peak current is 2.5Amp, whereas the average current is still 438mA @3.3V.

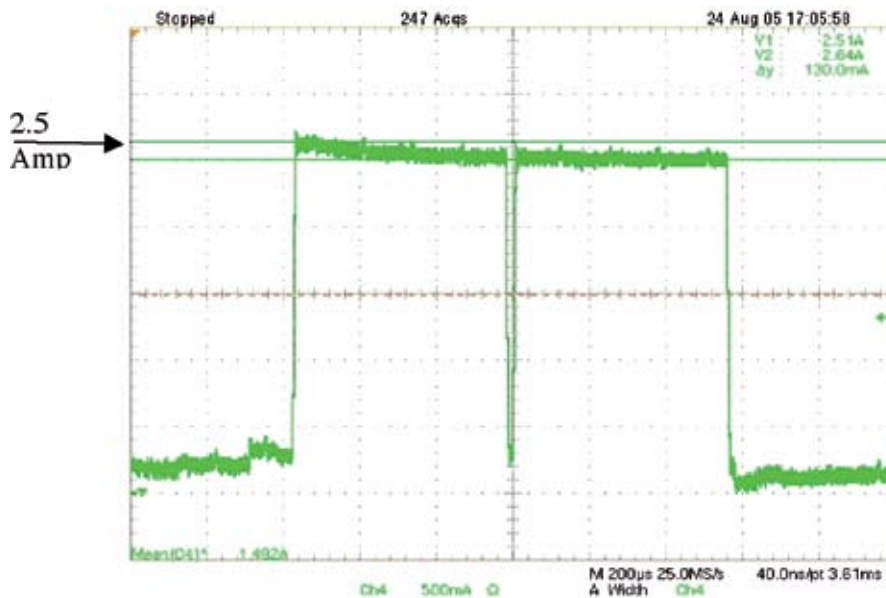

In the example above:

- The UE is a GPRS Multi Slot Class 10 with VSWR = 3.5 (bad antenna condition).
- 2 Tx Timeslots with a maximum of 8.
- Average current drawn is 438mA.

The host power must be capable of sourcing enough current to accommodate the maximum power when transmissions by the module come in bursts.



### Typical Current Measurements (Max. RF Tx-Power) in GSM with 1Tx @ 3.3V

| Band          | I <sub>mean nominal</sub> (mA) |
|---------------|--------------------------------|
| GSM 850 (128) | 438                            |
| EGSM(1)       | 363                            |
| PCS(512)      | 288                            |
| DCS(512)      | 272                            |

Note: The values in brackets are the channel numbers.

### Typical Current Measurements (Max. RF Tx-Power) in GPRS (MCS 1) @ 3.3V

| Band    | I <sub>mean nominal</sub> (mA) |               |           |           |
|---------|--------------------------------|---------------|-----------|-----------|
|         | 1Tx@ 32dBm                     | 2Tx @ 31.5dBm | 3Tx       | 4Tx       |
| GSM 850 | 260                            | 416           | 470@29dBm | 496@26dBm |
| EGSM    | 281                            | 452           | 555@30dBm | 598@28dBm |
| Band    | 1Tx@ 29dBm                     | 2Tx @ 29dBm   | 3Tx@29dBm | 4Tx@29dBm |
| PCS     | 216                            | 336           | 449       | 567       |
| DCS     | 223                            | 349           | 475       | 601       |

### Typical Current Measurements (Max. RF Tx-Power) in EDGE (MCS 5) @ 3.3V

| Band    | I <sub>mean nominal</sub> (mA) |               |            |            |
|---------|--------------------------------|---------------|------------|------------|
|         | 1Tx@ 27dBm                     | 2Tx @ 31.5dBm | 3Tx        | 4Tx        |
| GSM 850 | 228                            | 2Tx @ 27 dBm  | 3Tx@25 dBm | 4Tx@23 dBm |
| EGSM    | 241                            | 323           | 387        | 400        |
|         |                                | 338           | 404        | 419        |
| Band    | 1Tx@ 26dBm                     |               |            |            |
| PCS     | 219                            | 2Tx @ 26dBm   | 3Tx@26dBm  | 4Tx@26 dBm |
| DCS     | 229                            | 294           | 385        | 448        |

### 3.2.3 Current consumption in 3G in connected state

In 3G (WCDMA / HSDPA), the current is steady. There is no current pulse during connection as in 2G.

| Band      | I <sub>mean nominal</sub> (mA)         |  |                                |
|-----------|--|--|--------------------------------|
|           | WCDMA (64kbps UL /384kbps DL)<br>21dBm | WCDMA (64kbps UL /384kbps DL)<br>0 dBm | HSDPA (64kbps UL / 3.6Mbps DL) |
| I - 2100  | 573.25                                 | 365.6                                  | 605.4                          |
| II - 1900 | 637.2                                  | -                                      | 679.2                          |
| V - 850   | 673.2                                  | -                                      | 705                            |

## 4 Design guidelines

This section gives an overview of the main characteristics that can have an influence on the behaviour of the current flow in the MID, namely antenna mismatching and load transient.

### 4.1 Antenna Mismatching

MIDs are being used in many ways, but electronics in devices are optimized and frozen without the ability to be re-optimized for each mode of operation. Real-life conditions yield compromised performance vs. ideal lab conditions, sometimes by as much as a factor of 100. How users hold their devices can contribute to dropped or missed calls, poorer area coverage, shorter battery life and increased “network busy” conditions due to increased interference and lost network capacity.

Mismatches can occur for several reasons:

- Change in antenna environment, i.e. when the MIDs are held in a hand close to the antenna location, or on a metal cupboard.
- Temperature changes.
- Frequency band-edge coverage, especially for multi-frequency coverage that includes 3G.
- Cable losses between the antenna connection point of the module and the MID antenna can reach values up to 3dB.

Mismatch loss occurs at any point within the radio where a component RF input port or RF output port impedance is not 50 ohms. Components are typically connected in a series cascade configuration from the transceiver to the antenna, and all are designed to function optimally at 50 ohms. If the main transmit amplifier is connected to an unmatched impedance path, e.g. with an antenna cable having an input impedance other than 50 ohms, it begins to consume more DC power to make up for the impedance mismatch. Not only does this decrease efficiency, but amplifier linearity can also be severely degraded.

Measurements have been performed with varying VSWR (Voltage Standing Wave Ratio), and significant changes in the current and power consumption of the module can be noticed.

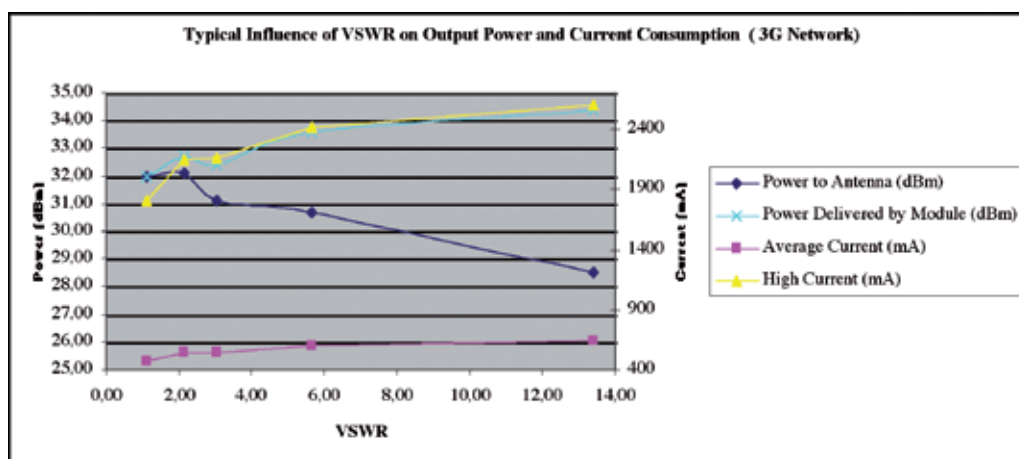

From the graph shown above, we can conclude that:

- When VSWR increases, the power that the module delivers will increase too and the power transmitted by the antenna will decrease.
- Because of the increase in delivered power, the current consumption will increase.

If the antenna impedance at the antenna connection of the module is not 50 ohms, performance also suffers. ‘Detuned’ antennas cause tremendous degradation to in-band performance. Objects near the antenna, for example the user’s ear or items on a table or briefcase, can detune antenna resonance and shift frequency response (frequencies at which an antenna radiates efficiently) down. Integrating the radio and antenna into a MID is challenging, especially for MIDs using internal antennas as opposed to external ones. This effort is often empirical and iterative. Good antenna performances are usually insured when the antenna designer is closely involved on the project from very early stage, especially during the hardware architectures definition.

### 4.2 Load Transient in Mobile Internet Devices

In 2G, the DC/DC converter should be capable of handling abrupt high current changes when the traffic arrives in bursts, and is defined as “load transient”. This is a key parameter when studying the current consumption of modules.

At the beginning of a transmit burst, the current value changes from its low level value to the high value. This value is the response of DC/DC converters due to the change.

The following graph shows the rising and falling edge of the current during the normal transmission between two bursts. The focus is on calculating the rise time of the current by taking steep rise points in the ramp (indicated in the graph with “x”) and showing that the load transient is about 292.5kA/sec, for this example.

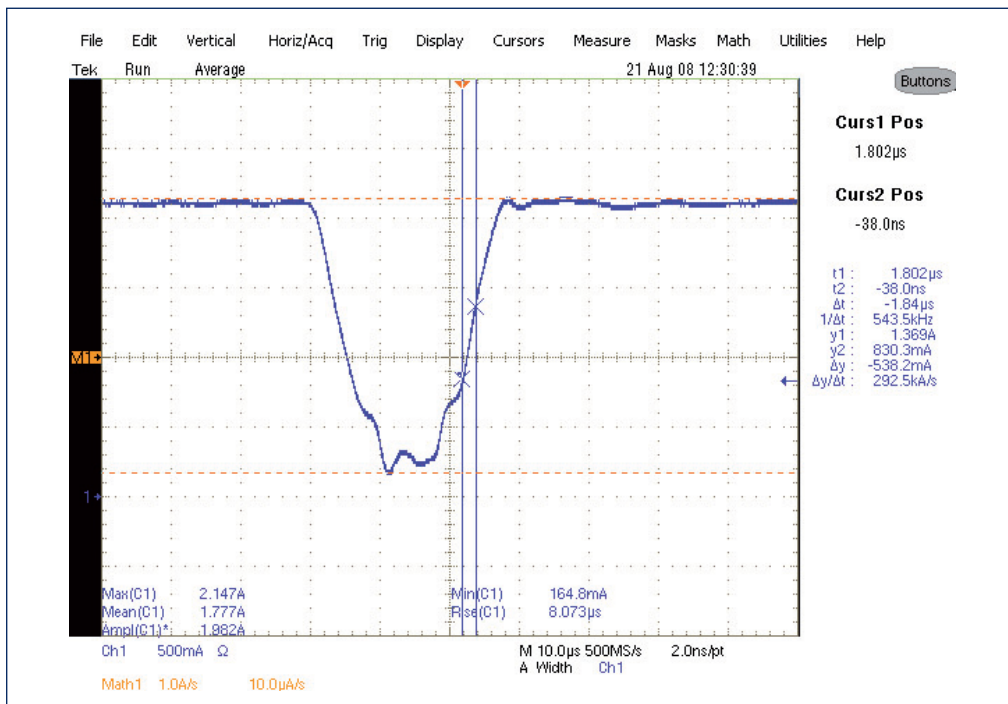

The next graph shows an example where the high current reaches 2.18A.

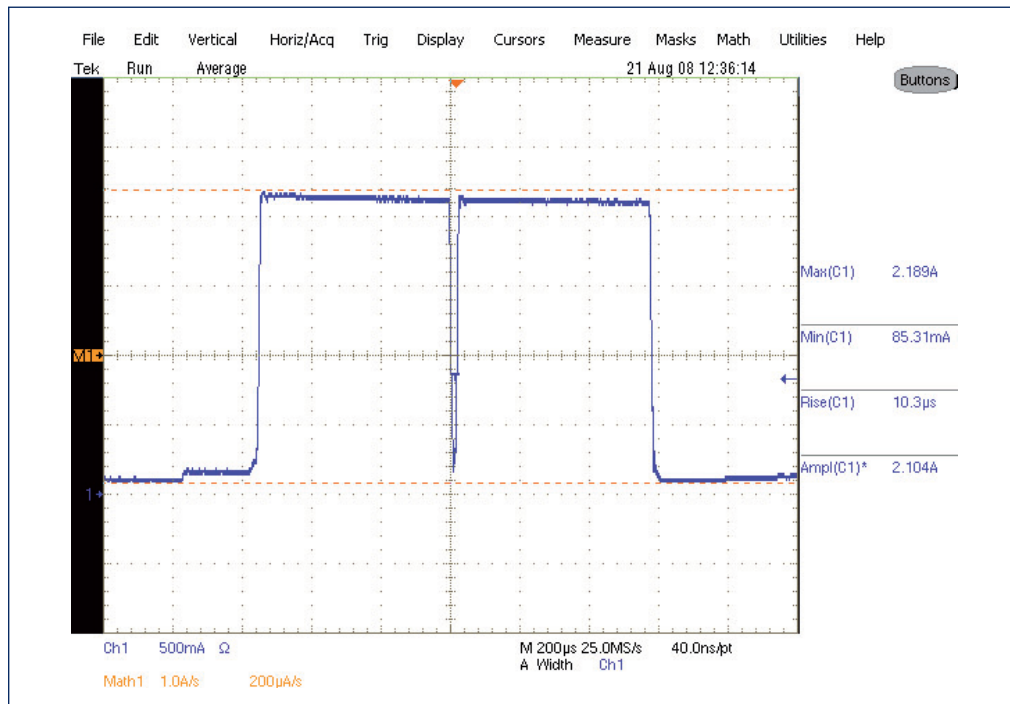

In this example, we can see that during a transmission with traffic bursts, the current ramps to 2.18A within 292.5kA/Sec and in worst case scenarios it can reach 2.5A within 400kA/sec. For integrators it is critical to have the load transient ripples optimized, so that this has minimum impact on system performance.

## 5 Conclusion

Power and current management have become critical issues in designing MIDs. They are affected by many parameters such as the number of Tx and Rx timeslots, in 2G or the Power states (e.g: power consumption is much higher in traffic mode than in idle mode)

In 2G the current is pulsed, as the transmitter is switched on in bursts. These bursts can have a load transient maximum of around 400kA/sec. The use of a step down switcher will be able to handle the very fast changes in transient current between the bursts. Also, the use of super capacitors on the power input on the host side is a possibility.

In general, the wireless module integrator should be aware that his device has to be able to deliver maximum currents of around 2.5A without having the supply voltage dropping below 3.3V.

When the VSWR value degrades, the module has to deliver more power to the antenna. Due to this mismatching, the power needed by the module's RF output power amplifier increases and the power received by the antenna decreases, which results in higher current consumption. The previous section on Antenna Mismatching demonstrates the consequences in both average and high currents.

In any system, optimal power transfer will occur when the source and load impedances match. If they are dif-

ferent, called a mismatch, then some of the power sent to the antenna will be reflected back into the load or lost as heat. This will lower the efficiency of the system, lowering range, increasing power requirements and shortening battery life.

Module integrators should also be aware of the following:

- Understanding and specifying load transient response during the design of an MID is necessary to avoid higher current consumption (especially in 2G) and also to avoid errors in high data rate wireless transmission.
- Antenna mismatching can be reduced by placing the matching networks close to the antenna. The impedance of the source should be as close to 50 ohms as possible, so as to ensure no unnecessary extra current or power is drawn because of this mismatching.
- The response times for moving from power saving modes to operation modes are critical for many real-time applications

## 6 About Option

Option, the wireless technology company, designs, develops, and manufactures devices that provide high-quality wireless access to the Internet via 3G HSPA technologies.

The company has established an impressive reputation for creating exciting products that enhance the performance and functionality of wireless communications. Since our inception we have realized no less than 15 world-firsts in the wireless industry.

The world's leading mobile telecom operators guarantee their mass market and professional customers easy and reliable wireless Internet access through our data cards and USB devices.

Today, our products are used around the world. The world's top manufacturers of notebooks and consumer electronics incorporate our wireless Internet access modules into their new lines of laptops and mobile internet devices. Option's GTM 501 is currently the world's smallest wireless module and the only 3G module available today in the same LGA form factor that has been proposed for WiMAX.

We also offer our customers the appropriate, user-friendly Internet connection software written specifically for the mobile environment.

Option is headquartered in Leuven, Belgium. The company conducts its Research & Development in Leuven and Düsseldorf, Germany. The Düsseldorf facility is currently developing comprehensive test facilities that are intended to secure accreditation as "Trusted Labs" from the major mobile operator groups. This will enable Option to accelerate the certification process of its own modules and third party MIDs incorporating Option modules.

Software development is undertaken by a specialist team in Adelsried, Germany while our ISO 9001 production engineering and logistics facility is located in Cork, Ireland. Option also maintains offices in Europe, US, Asia, Japan and Australia.

For more information please visit [www.option.com](http://www.option.com).

## 7 References

- 3GPP TR 25.480 “Terminal Power Saving features”.
- ETSI TS 151 010 -1 v7.8.0 “Mobile Station (MS) Conformance specification”.
- ETSI TS 134 121-1 v8.2.1 “UE Conformance Specification; Radio transmission and reception”.

## 8 Glossary

**GSM:** Global System for Mobile Communication is a digital mobile telephone system that is widely used in Europe and other parts of the world. GSM uses a variation of Time Division Multiple Access (TDMA) and is the most widely used of the three digital wireless telephone technologies (TDMA, GSM and CDMA). GSM digitizes and compresses data, then sends it down a channel with two other streams of user data, each in its own time slot. It operates at either the 900 MHz or 1800 MHz frequency band.

**GPRS:** General Packet Radio Service is a standard for wireless communications which runs at speeds up to 115 kilobits per second, compared with current GSM (Global System for Mobile Communication) systems' 9.6 kilobits. GPRS, which supports a wide range of bandwidths, is an efficient use of limited bandwidth and is particularly well suited for sending and receiving small bursts of data such as e-mail and web browsing, in addition to large volumes of data.

**EDGE:** Enhanced Data rate for GSM Evolution is a faster version of the Global System for Mobile Communication (GSM) wireless service, designed to deliver data at rates up to 384 Kbps and enable the delivery of multimedia and other broadband applications to mobile phone and computer users. The EDGE standard is built on the existing GSM standard, using the same time-division multiple access (TDMA) frame structure and existing cell arrangements.

**WCDMA:** Wideband Code Division Multiple Access is the radio access scheme used for third generation cellular systems that are being rolled out in various parts of the globe. The 3G systems support wideband services (like high-speed internet access, video and high quality image transmission) with the same quality as the fixed networks. In WCDMA systems the CDMA air interface is combined with GSM based networks. The WCDMA standard was evolved through the Third Generation Partnership Project (3GPP) which aims to ensure interoperability between different 3G networks.

**Frequency Division Duplex (FDD):** FDD means that the radio transmitter and receiver operate at different frequencies. This mode of operation is referred to as duplex mode or offset mode. Uplink and downlink sub-bands are said to be separated by the “frequency offset”. Frequency division duplex or frequency duplex is much more efficient when there is symmetric traffic. In this case TDD tends to waste bandwidth during switchover from transmit to receive, has greater inherent latency and may require more complex, more power-hungry circuitry.

**Average Current (during call):** The highest average current value over any 600 ms period. Sampling rate: 15.7µs

**Average Current (during idle mode):** The highest average current value over any 10 minute period. Sampling rate: 100 $\mu$ s

**High current:** The highest averaged current value over any 100 $\mu$ s period. Sampling rate: 15.7 $\mu$ s

**Low current:** The lowest averaged current value over any 100 $\mu$ s period. Sampling rate: 15.7 $\mu$ s

### 3GPP Frequency Bands

| Designed Spectrum | 3GPP Band | Uplink      | Downlink    | Bandwidth | Channel Spacing |
|-------------------|-----------|-------------|-------------|-----------|-----------------|
| UMTS 2100         | Band I    | 1920 - 1980 | 2110 - 2170 | 60MHz     | 190MHz          |
| UMTS 1900         | Band II   | 1850 - 1910 | 1930 - 1990 | 60MHz     | 80MHz           |
| UMTS 1800         | Band III  | 1710 - 1785 | 1805 - 1880 | 75MHz     | 95MHz           |
| AWS               | Band IV   | 1710 - 1755 | 2110 - 2155 | 45MHz     | 400MHz          |
| UMTS 850          | Band V    | 824 - 849   | 869 - 894   | 25MHz     | 45MHz           |
| UMTS 800          | Band VI   | 830 - 840   | 875 - 885   | 10MHz     | 45MHz           |
| UMTS 2600         | Band VII  | 2500 - 2570 | 2620 - 2690 | 70MHz     | 120MHz          |
| UMTS 900          | Band VIII | 880 - 915   | 925 - 960   | 35MHz     | 45MHz           |
| UMTS 1700         | Band IX   | 1750 - 1785 | 1845 - 1880 | 35MHz     | 95MHz           |

**VSWR: Voltage Standing Wave Ratio:** The ratio of maximum voltage to minimum voltage in a transmission medium.  $VSWR = V_{max}/V_{min}$ , where  $V_{max}$  is the voltage level of the transmitted wave and  $V_{min}$  is the voltage level of the reflected wave

If the characteristic impedance of the medium is equal to load impedance, then VSWR is optimal and equals 1. If the characteristic impedance ( $Z_0$ ) is less than the load impedance ( $Z_L$ ), then VSWR is greater than 1.

**Note:** The VSWR is a measure of impedance mismatch between the transmission line and its load. The higher the VSWR, the greater the mismatch. The minimum VSWR, i.e. that which corresponds to a perfect impedance match, is equal to 1.



